

## NUMERICAL SOLUTION OF THE 1-D DIFFUSION EQUATION (39)

### I Main Topics

- A Motivation: Why use a numerical technique?
- B Non-dimensionalizing the diffusion (heat flow) equation
- C Solution of heat flow equation using finite-difference approximation  
**See the figures on pages 5 and 8!**

### II Motivation: Why use a numerical technique?

- A It provides a useful alternative insight into the second order PDE (partial differential equation) for transient flow
- B It provides useful insight into the influence of different initial conditions and boundary values on the solution to the equation
- C It is useful for investigating a wide range of initial value/boundary value combinations and geometries. In contrast, analytical solutions are available only for a small range of initial value/boundary value combinations and for simple geometries.
- D Finite-difference technique is a good learning tool, in spite of its limitations (e.g., need for fine mesh locally, numerical errors).

### III Non-dimensionalizing the heat flow equation

$$\frac{\partial T}{\partial t} = \kappa \frac{\partial^2 T}{\partial x^2} \quad (39.1)$$

where  $T$  = temperature,  $\kappa$  is the thermal diffusivity (=  $1/C$  of lecture 38), and  $x$  is position.  $T$  and  $x$  are variables, and we assume  $K$  is a constant.

"Nondimensionalizing" (or scaling) the equation eliminates the term  $K$ .

Let  $x^* = x/x_{\max}$ ,  $t^* = \kappa t/x_{\max}^2$ , and  $T^* = T/T_{\max}$

or  $x = x^* x_{\max}$ ,  $t = t^* x_{\max}^2/\kappa$ , and  $T = T^* T_{\max}$ .

Note that all the starred terms are dimensionless numbers. The terms  $x_{\max}$  and  $T_{\max}$  are the scaling terms and are constants. The chain rule will be used to rewrite (39.1), so we take derivatives of  $x$ ,  $t$ , and  $T$ :

$$dx/dx^* = x_{\max} = 1/(dx^*/dx) = 1/(1/x_{\max}) \quad (39.2)$$

$$dt/dt^* = x_{\max}^2/\kappa = 1/(dt^*/dt) = 1/(\kappa/x_{\max}^2) \quad (39.3)$$

$$dT^*/dT = 1/T_{\max} \quad (39.4)$$

We will re-write the left side of (39.1) first - it involves only a first-order derivative. We will then attack the “harder” right side of (39.1).

Now the chain rule is brought to bear. In the equations below pay attention to which terms are derivatives and which are constants.

$$\frac{\partial T^*}{\partial t^*} = \frac{\partial T}{\partial t} \frac{dT^*}{dT} \frac{dt}{dt^*} = \frac{\partial T}{\partial t} \frac{1}{T_{\max}} \frac{(x_{\max})^2}{\kappa} \quad (39.5)$$

We solve for  $\frac{\partial T}{\partial t}$  to express the left side of (39.1) in dimensionless terms.

$$\frac{\partial T}{\partial t} = \frac{\partial T^*}{\partial t^*} (T_{\max}) \frac{\kappa}{(x_{\max})^2} \quad (39.6)$$

We are done with the left side of (39.1) and move to the right side.

$$\frac{\partial T^*}{\partial x^*} = \frac{\partial T}{\partial x} \frac{dT^*}{dT} \frac{dx}{dx^*} = \frac{\partial T}{\partial x} \frac{1}{T_{\max}} x_{\max} \quad \text{(First derivative)} \quad (39.7)$$

$$\frac{\partial^2 T^*}{\partial x^{*2}} = \frac{\partial \left[ \frac{\partial T^*}{\partial x^*} \right]}{\partial x^*} = \frac{\partial \left[ \frac{\partial T^*}{\partial x^*} \right]}{\partial x} \frac{dx}{dx^*} = \frac{\partial \left[ \frac{\partial T}{\partial x} \frac{1}{T_{\max}} x_{\max} \right]}{\partial x} x_{\max} \quad (39.8)$$

$$\frac{\partial^2 T^*}{\partial x^{*2}} = \frac{\partial^2 T}{\partial x^2} \frac{1}{T_{\max}} (x_{\max})^2 \quad (39.9)$$

Substituting (39.6) and (39.9) into (39.1) yields:

$$\frac{\partial T^*}{\partial t^*} (T_{\max}) \frac{\kappa}{(x_{\max})^2} = \kappa \frac{\partial^2 T^*}{\partial x^{*2}} \frac{T_{\max}}{(x_{\max})^2} \quad (39.10)$$

By eliminating the three terms common to both sides, this reduces to

$$\frac{\partial T^*}{\partial t^*} = \frac{\partial^2 T^*}{\partial x^{*2}} \quad (T^*, x^*, \text{ and } t^* \text{ are dimensionless}) \quad (39.11)$$

### III Finite-difference solution to the 1-D heat equation (diffusion equation)

The first step we take is to set up a dimensionless grid. The size of our  $\Delta x^*$  and  $\Delta t^*$  steps are equal, so this is a square mesh (note: this could mean that either  $\Delta x$  or  $\Delta t$  is awkwardly small):

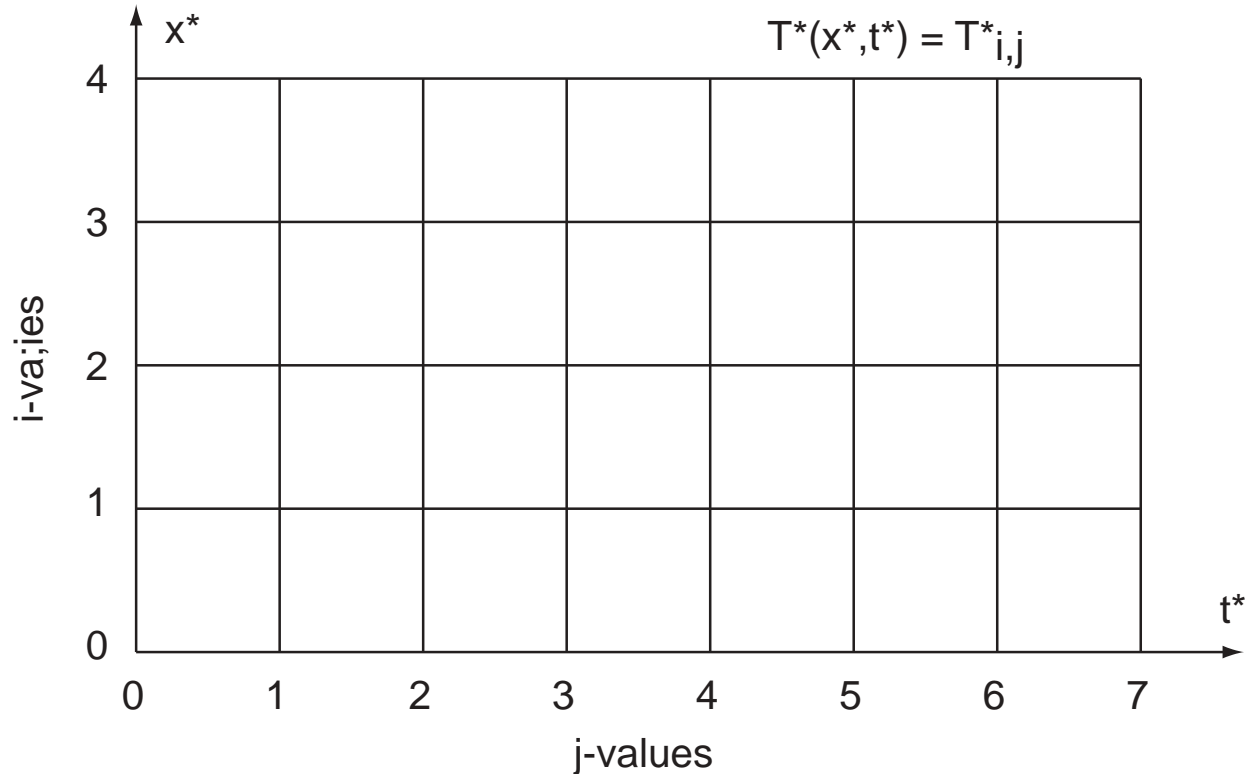

There are two terms that need to be approximated:  $\partial T^*/\partial t^*$ , and  $\partial^2 T^*/\partial x^{*2}$ . We make use of the definition of a partial derivative to do this (also see the next figure).

$$\frac{\partial T^*}{\partial t^*} \approx \frac{[T^*(x^*, t^* + \Delta t^*) - T^*(x^*, t^*)]}{\Delta t^*} \quad (39.12)$$

In terms of the grid parameters  $i$  and  $j$ , this is

$$\frac{\partial T^*}{\partial t^*} \approx \frac{[T^*_{i,j+1} - T^*_{i,j}]}{\Delta t^*} \quad (39.13)$$

As to the second derivatives

$$\frac{\partial^2 T^*}{\partial x^{*2}} \approx \frac{\partial \left( \frac{\partial T^*}{\partial x^*} \right)}{\partial x^*} \quad (39.14)$$

$$\frac{\partial^2 T^*}{\partial x^{*2}} \approx \frac{\left(\frac{\partial T^*}{\partial x^*}\right)_{i+1/2,j} - \left(\frac{\partial T^*}{\partial x^*}\right)_{i-1/2,j}}{\Delta x^*} \quad (39.15)$$

The terms in the square brackets are partial derivatives, the first taken at point  $(i+1/2, j)$  and the second at point  $(i-1/2, j)$ .

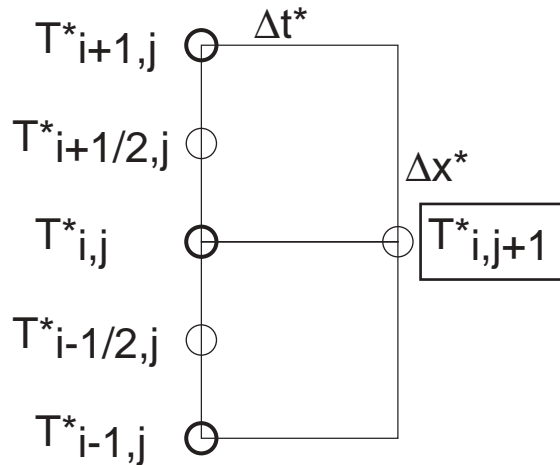

The second partial derivative of  $T^*$  with respect to  $x^*$  at the point  $(i, j)$  is approximately equal to the change in the first partial derivative with respect to  $x^*$  between points  $(i+1/2, j)$  and  $(i-1/2, j)$ , divided by  $\Delta x^*$  [the distance in space between the points  $(i+1/2, j)$  and  $(i-1/2, j)$ ].

$$\frac{\partial^2 T^*}{\partial x^{*2}} \approx \frac{\frac{T^*_{i+1,j} - T^*_{i,j}}{\Delta x^*} - \frac{T^*_{i,j} - T^*_{i-1,j}}{\Delta x^*}}{\Delta x^*} \quad (39.16)$$

$$\frac{\partial^2 T^*}{\partial x^{*2}} \approx \frac{T^*_{i+1,j} - 2T^*_{i,j} + T^*_{i-1,j}}{(\Delta x^*)^2} \quad (39.17)$$

So equation (39.11) can be written in finite difference form as

$$\frac{T^*_{i,j+1} - T^*_{i,j}}{\Delta t^*} \approx \frac{T^*_{i+1,j} - 2T^*_{i,j} + T^*_{i-1,j}}{(\Delta x^*)^2} \quad (39.18)$$

This equation can be solved for  $T^*_{i,j+1}$ :

$$T^*_{i,j+1} \approx \left[ 1 - \left( \frac{2\Delta t^*}{(\Delta x^*)^2} \right) \right] T^*_{i,j} + \left\{ \frac{\Delta t^*}{(\Delta x^*)^2} \right\} [T^*_{i+1,j} + T^*_{i-1,j}] \quad (39.19)$$

The terms in the braces can be considered as weighting terms. In that context, equation (39.19) says (see the above figure!) that the value of  $T^*_{i,j+1}$  can be obtained from a weighted average of the nearest three points at the previous time step. In practice, this only works if  $\Delta t^*/[\Delta x^*]^2 \leq 1/2$  (i.e.,  $\Delta t^* \leq 1/2 [\Delta x^*]^2$ ), so  $\Delta t^*$  needs to be impractically tiny. This is because the approximations used here for the partial derivatives aren't sufficiently accurate unless  $\Delta t^*$  is really small.

To do a better job, we use the Crank-Nicholson technique for approximating the partial derivatives. This technique relies on using the values at **four** surrounding nodes instead of three, and leads to an amazingly simple equation that gives a considerable amount of insight into the nature of our differential equation.

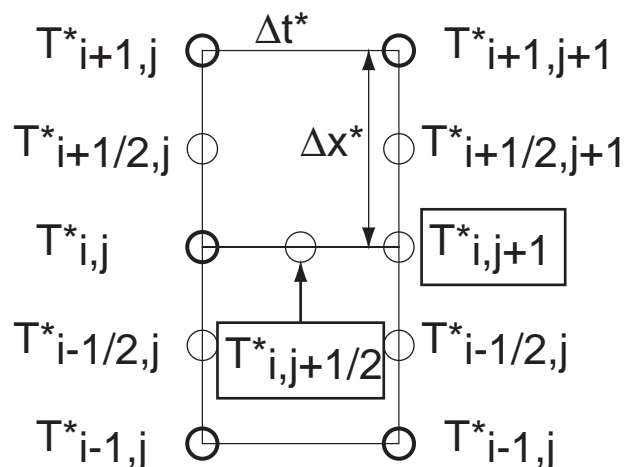

The Crank-Nicholson technique works by finding the derivatives at point  $(i, j+1/2)$ , that is, at the midpoint on the line shared by the two boxes show above, instead of at point  $(i, j)$ . This is because equation (39.13)

$$\frac{\partial T^*}{\partial t^*} \approx \frac{[T^*_{i,j+1} - T^*_{i,j}]}{\Delta t^*} \quad (39.13)$$

is a better approximation of the derivative at point  $(i, j+1/2)$  than at point  $i,j$  (see the handout on derivatives).

To evaluate  $\partial^2 T^*/\partial x^{*2}$  at point  $(i, j+1/2)$ , we take the average of  $\partial^2 T^*/\partial x^{*2}$  at points  $(i, j)$  and  $(i, j+1)$ . The value of this derivative at point  $(i, j)$  is:

$$\left. \frac{\partial^2 T^*}{\partial x^{*2}} \right|_{i,j} \approx \frac{T^*_{i+1,j} - 2T^*_{i,j} + T^*_{i-1,j}}{(\Delta x^*)^2} \quad (39.20)$$

The value of  $\partial^2 T^*/\partial x^{*2}$  at point  $(i, j+1)$  is approximated by permuting the indices in the previous expression:

$$\left. \frac{\partial^2 T^*}{\partial x^{*2}} \right|_{i,j+1} \approx \frac{T^*_{i+1,j+1} - 2T^*_{i,j+1} + T^*_{i-1,j+1}}{(\Delta x^*)^2} \quad (39.21)$$

The value of  $\partial^2 T^*/\partial x^{*2}$  at point  $(i, j+1/2)$  is thus approximated by:

$$\left. \frac{\partial^2 T^*}{\partial x^{*2}} \right|_{i,j+1/2} \approx \frac{1}{2} \left. \frac{\partial^2 T^*}{\partial x^{*2}} \right|_{i,j} + \frac{1}{2} \left. \frac{\partial^2 T^*}{\partial x^{*2}} \right|_{i,j+1} \quad (39.22)$$

Because of the inherently greater accuracy of this technique, we can let  $\Delta t^* = \Delta x^*$  (we couldn't do this with our first technique; see the comment on the previous page). We can pick values of  $\Delta t$  and  $\Delta x$  that give us whatever values we wish for  $\Delta t^*$  and  $\Delta x^*$ . We now set  $\Delta t^*$  and  $\Delta x^*$  equal to one, and the expressions for the derivatives simplify greatly.

$$\left. \frac{\partial T^*}{\partial t^*} \right|_{i,j+1/2} \approx T^*_{i,j+1} - T^*_{i,j} \quad (39.23)$$

$$\left. \frac{\partial^2 T^*}{\partial x^{*2}} \right|_{i,j} \approx T^*_{i+1,j} - 2T^*_{i,j} + T^*_{i-1,j} \quad (39.24)$$

By permuting the indices of (24) we obtain

$$\left. \frac{\partial^2 T^*}{\partial x^{*2}} \right|_{i,j+1} \approx T^*_{i+1,j+1} - 2T^*_{i,j+1} + T^*_{i-1,j+1} \quad (39.25)$$

Now use equation (39.22) to find  $\partial^2 T^*/\partial x^{*2}$  at point  $(i, j+1/2)$

$$\begin{aligned} \left. \frac{\partial^2 T^*}{\partial x^{*2}} \right|_{i,j+1/2} &\approx \frac{1}{2} \{ T^*_{i+1,j} - 2T^*_{i,j} + T^*_{i-1,j} \} \\ &+ \frac{1}{2} \{ T^*_{i+1,j+1} - 2T^*_{i,j+1} + T^*_{i-1,j+1} \} \end{aligned} \quad (39.26)$$

Now expressions (39.23) and (39.26) are set equal to give the finite difference approximation of equation (39.11)

$$\begin{aligned} T^*_{i,j+1} - T^*_{i,j} &\approx \frac{1}{2} \{ T^*_{i+1,j} - 2T^*_{i,j} + T^*_{i-1,j} \} \\ &+ \frac{1}{2} \{ T^*_{i+1,j+1} - 2T^*_{i,j+1} + T^*_{i-1,j+1} \} \end{aligned} \quad (39.27)$$

Multiplying both sides of (39.27) by 2

$$\begin{aligned} 2\{T^*_{i,j+1} - T^*_{i,j}\} &\approx \{T^*_{i+1,j} - 2T^*_{i,j} + T^*_{i-1,j}\} \\ &+ \{T^*_{i+1,j+1} - 2T^*_{i,j+1} + T^*_{i-1,j+1}\} \end{aligned} \quad (39.28)$$

Now like terms are collected and the terms  $- 2T^*_{i,j}$  on both sides of (39.28) are dropped.

$$\{T^*_{i+1,j} + T^*_{i-1,j}\} + \{T^*_{i+1,j+1} + T^*_{i-1,j+1}\} - 4T^*_{i,j+1} = 0 \quad (39.29)$$

Now the term  $T^*_{i,j+1}$  is solved for

$$\frac{1}{4} \{T^*_{i+1,j} + T^*_{i-1,j} + T^*_{i+1,j+1} + T^*_{i-1,j+1}\} = T^*_{i,j+1} \quad (39.30)$$

Equation (39.30) states that equation (39.11) can be thought of as saying the value of T at any node is equal to the average value of the two adjacent nodes at the same time step and the two nodes at the preceding time step! This is a startlingly simple way to view the second order partial differential equation we began with. No derivatives are involved (at least not explicitly) in (39.30). To see this point graphically, examine the above diagram. Two other key points are: (1) one can see how the state of the system at one step will effect the state at a subsequent time step, and (2) one can see how the boundary conditions effect the interior.

Two closing comments. First, the finite-difference solution of the partial differential equations presented here turns out to be essentially an averaging procedure, and this is a useful way of viewing the way the system is trying to respond (i.e., how "information" propagates within the system). Second, a side-by-side comparison of the finite-difference solutions for the Laplace equation and the heat equation is interesting:

Laplace Equation

$$\frac{\partial^2 T}{\partial x^2} + \frac{\partial^2 T}{\partial y^2} = 0$$

1-D Heat (Diffusion) Equation

$$\frac{\partial^2 T}{\partial x^2} = \frac{\partial T}{\partial t}$$

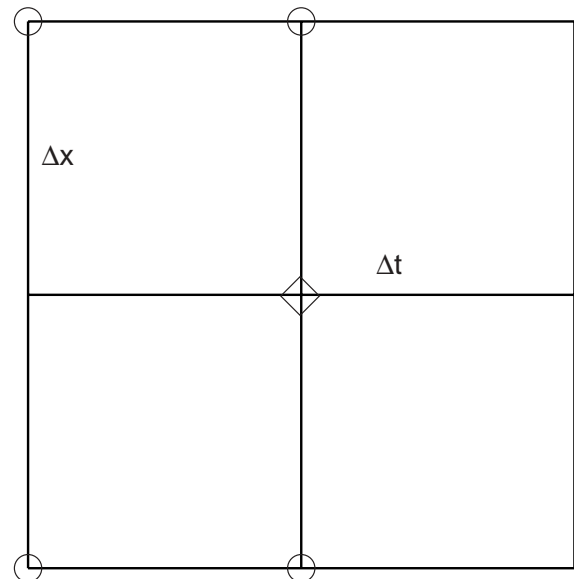
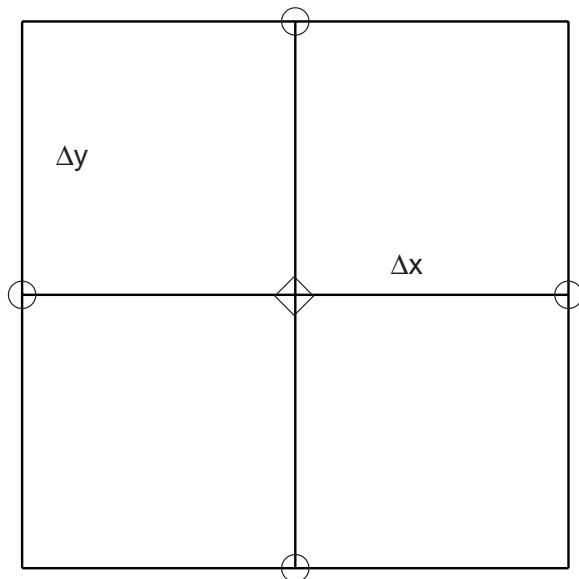

In both cases, the value of  $T$  at the node marked by a diamond is approximately the average of the  $T$  values at the circled nodes.

The expressions on the first page of this lecture would be used to convert the dimensionless solutions to dimensioned solutions:

$$x = x^* x_{\max},$$

$$t = t^* x_{\max}^2 / K,$$

and

$$T = T^* T_{\max}$$