

### 3. ORTHOGRAPHIC PROJECTIONS

#### I Main Topics

A Introduction to orthographic projections

B Three rules

C Examples

8/25/11

GG303

1

### 3. ORTHOGRAPHIC PROJECTIONS

#### II Introduction to orthographic projections

A Provide two-dimensional representations of objects

B Points are projected such that lines of projection are all parallel and hence are all perpendicular to a single plane

C Points project as points

D A line projects as a point only if viewed parallel to its length

E A plane projects as a line only if viewed edge-on (parallel to the plane)

8/25/11

GG303

2



### 3. ORTHOGRAPHIC PROJECTIONS

#### IV Examples

A Points

B Lines

C Planes

8/25/11

GG303

5

8/25/11

GG303

6

## Orthographic Projections of a Point

Fig. 3.1.a

The front and right views are both adjacent to the top view. The front view is perpendicular to the top view, and the top view is perpendicular to the right view ; adjacent views are perpendicular to each other. The projection or tie lines (thin lines) are viewing direction lines and are perpendicular to the fold lines (dashed lines). The front view (F) and right view (R) are related. Two adjacent views give enough information to construct a third view. For example, the top view and front view could be used to construct the right view: Point P is on projection lines perpendicular to the fold lines, and the front view tells us that point P is a distance  $z_p$  from the top. Similarly, the front view could be created from the top view and the right view. Both the front and right views give the distance  $z_p$  of point P from the top.

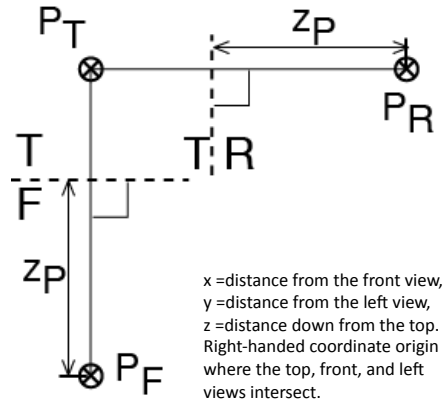

8/25/11

GG303

7

## Orthographic Projections of a Point

Fig. 3.1.b

Here the right view is drawn adjacent to the front view. The top and right views are related. The top and right views are both adjacent to the front view. Both the top and right views give the distance  $x_p$  of point P from the front.

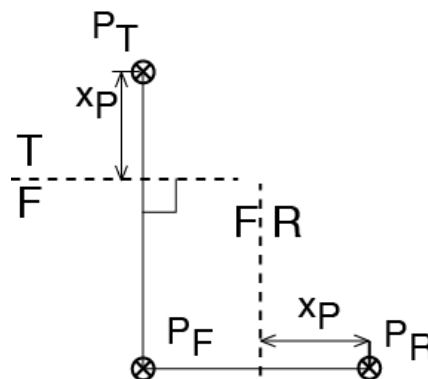

8/25/11

GG303

8

## Orthographic Projections of a Point

Fig. 3.1.c

The front view and view "A" are related. Both are adjacent to the top view, and both give the distance  $z_p$  of point P from the top.

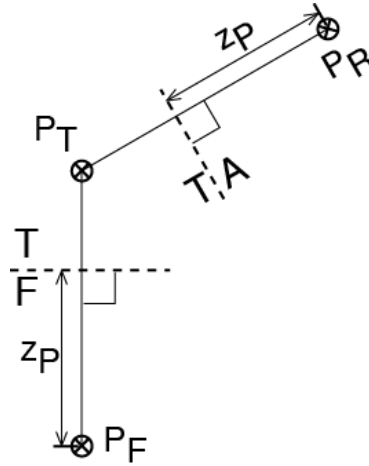

8/25/11

GG303

9

## Orthographic Projections of a Point

Fig. 3.1.d

The top and view "B" are related. Both are adjacent to the front view, and both give the distance  $x_p$  of point P from the front.

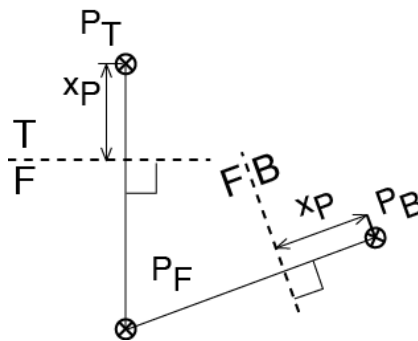

8/25/11

GG303

10

## Orthographic Projections of a Line

Fig. 3.2.a

A line is defined by two points. Suppose we have with the information above. The two views provide information on the left-right, up-down, and front-back coordinates of the points, so that gives complete information on their positions.

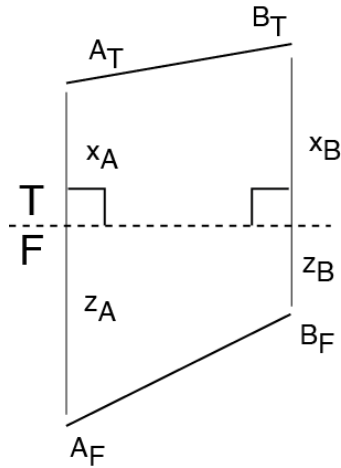

8/25/11

GG303

11

## Orthographic Projections of a Line

Fig. 3.2.b

This is how line AB projects into a right view adjacent to the top view. We just use the procedure for projecting a single point twice, once for each point, and connect the dots.

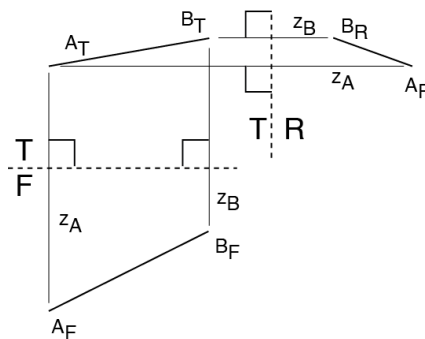

8/25/11

GG303

12

## Orthographic Projections of a Line

Fig. 3.2.c

This is how line AB would project into a right view adjacent to the front view.

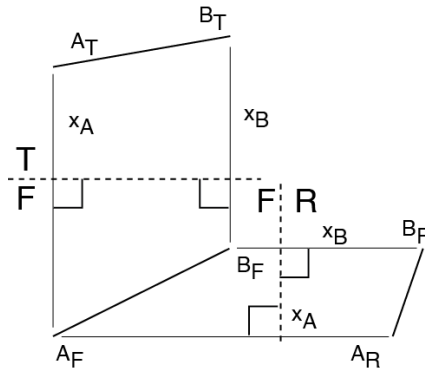

8/25/11

GG303

13

## Orthographic Projections of a Line

Fig. 3.2.d

To find the length and plunge of AB we take a cross section parallel to the trend of the line (the trend is given in the top view). The length and plunge are in view C, adjacent to the top. A view "down the line" gives the end-on view of the line (view D) in which the line appears as a point.

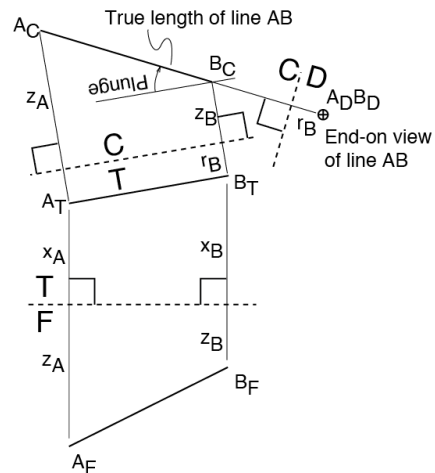

8/25/11

GG303

14

## Orthographic Projections of a Plane

Fig. 3.3.a

Three points define a plane. The two adjacent views here give complete information on the positions of three points defining plane ABC. This information might come from a cross section or a map.

Suppose we want to know the strike and dip of plane ABC. We first need to find the strike of the plane. The line of strike is a horizontal line in plane ABC.

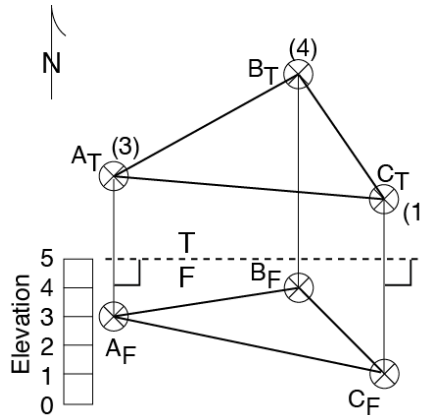

8/25/11

GG303

15

## Orthographic Projections of a Plane

Fig. 3.3.b

We find the line of strike by intersecting a horizontal plane with plane ABC. We start with a vertical view (here that is the front view F) and then project the line of strike into the top view T. The strike of the plane is measured in the top view by finding the direction of the (horizontal) line of strike. The numbers in parentheses in the top view are elevations, taken from the front view.

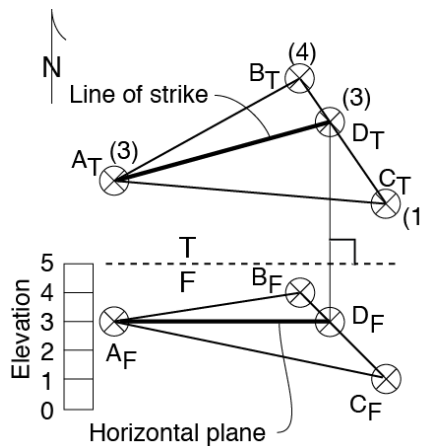

8/25/11

GG303

16



# Orthographic Projections of a Plane

Fig. 3.3.c

Take an auxiliary view cross section perpendicular to the line of strike to get the dip of the plane. The line of strike will be viewed end-on and horizontally, and it will appear as a point. The plane will appear edge-on as a line. The inclination of the plane below the horizontal is the dip; it is measured here in view A. Because the top plane T is horizontal, the intersection of T and A is horizontal.

